

---

## Energy-Efficient Residue Number System (EERNS) Based Wireless Sensor Networks in Healthcare Systems

Olorunesan Sunday Akinyemi <sup>1</sup> Lukumon Olawale Olatunbosun <sup>2</sup>

Oluwole. A. Oyinlola <sup>3</sup> Sulaimon. O Abdul-Salam <sup>4</sup> Kazeem. A. Gbolagade <sup>5</sup>

<sup>1</sup> Computer Science Department, Ogun State D.S Adegbenro ICT Polytechnic. Itori, Nigeria

<sup>2</sup> Information and Communication Technology Department, Federal University of Agriculture Abeokuta

<sup>3</sup> Computer Science Department, College of Information & Communication Technology Kwara State University  
Malete, Nigeria

<sup>4</sup> Computer Science Department, College of Information & Communication Technology Kwara state  
University Malete, Nigeria

<sup>5</sup> Computer Science Department, College of Information & Communication Technology kwara state University  
Malete, Nigeria

doi: <https://doi.org/10.37745/ejcsit.2013/vol14n43947>

Published June 28, 2026

---

**Citation:** Akinyemi O.S., Olatunbosun L.O., Oyinlola O.A., Abdul-Salam S.O., Gbolagade K.A. (2026) Energy-Efficient Residue Number System (EERNS) Based Wireless Sensor Networks in Healthcare Systems, *European Journal of Computer Science and Information Technology*, 14(4),39-47

---

**Abstract:** *Amongst the numerous Technological Advancements (TA) in the healthcare service delivery system, Wireless Sensor Networks (WSNs) have played a pivotal role in how networks handle the collection and processing of patient's data from cognitive, physical, physiological, and behavioral patterns, (WSNs) in healthcare system have bridged the gap and enhance the standard by which healthcare practitioners monitor, collect and interpret data through sensor node from patients however; this has brought peculiar challenges such as noise, speed memory utilization, overflow detection along with it. There is an emphasis on time when monitoring and diagnosing patients. WSNs based on the Residue Number System (RNS) offer time-sensitive interventions through wearable and implantable sensors, which can enhance numerous issues in the healthcare service delivery system. The potential benefits of these systems are significant, but the main barriers to adoption include poor energy performance, delayed processing, and security concerns. This study adopts RNS arithmetic, which operates independently between residues by executing position-independent operations that lead to both improved processor speed and parallel computing capability. WSNs leverage this mathematical approach because of their resource constraints during operation. medical practitioners researchers have relied on various methods for the collection of patient data, which have often shown some inconsistencies like manual measurement using stethoscopes instruments and a thermometer, etc.; these existed constraints where healthcare providers are limited in their ability to share patient's data between themselves. Result finding in this work WSNs based RNS has proved against this backdrop that network has shown to be a game changer in the healthcare sector.*

**Keywords:** wireless sensor network (WSN), residue number system (RNS), healthcare service delivery system

---

## INTRODUCTION

Amongst the numerous technological advances in the healthcare settings, Wireless Sensor Networks have played a pivotal role in how networks handle the collection and processing of patient's data from cognitive, physical, physiological, and behavioral patterns, either from their personal space or a large space like a hospital. Previously, medical practitioners relied on various methods for the collection of patient data, which have often proven to be inconsistent and unreliable. Some of such methods include manual measurement using instruments like stethoscopes and a thermometer, to mention a few; others include recording and storing this data from patients on paper which can get damaged with time; and lastly, they existed constraints whereby healthcare providers are limited in their ability to share patients' data between themselves. It is against this backdrop that this network has proven to be a game changer in the healthcare sector. WSNs in the healthcare settings have bridged the gap and improve the standard by which healthcare practitioners monitor, collect and interpret data through sensor node from patients but this has brought peculiar challenges along with it. There is an emphasis on time when monitoring and diagnosing patients since WSNs offer these time-sensitive interventions through wearable and implantable sensors which have the capacity to redefine healthcare practices, numerous issues restrict the realization of WSN based healthcare systems despite their potential benefits, the main barriers against their adoption include poor energy performance combined with delayed processing and security dangers. Standard number system or Traditional number systems have hindered the computational efficiency of WSNs in Healthcare, leading to delays in real time monitoring. Additionally, security vulnerabilities that stems from the poor performance have often proven to threaten patient data (JG Ko *et al*, 2024). For example, WSNs is used widely for electrocardiogram (ECG) monitoring on heart activities in real time for patients who suffer from cardiovascular conditions, where outcomes are classified as volatile and very sensitive.

## LITERATURE REVIEW

Wireless Sensor Networks (WSNs) is an essential tool for live healthcare monitoring information. The work utilizes sensor nodes positioned at different sites, which monitor essential health indicators. These sensors become valuable because they use wireless communication, which allows them to function in all healthcare facilities (Chakraborty *et al.*, 2023). Wearable devices built upon WSNs perform wearable devices are incorporated into machine learning (ML) algorithms, which enhance their capacity for providing accurate health data fidelity Enables Doctors to obtain visible patients' vital signs from remote distances due to modern advancements in technology. (He *et al.*, 2023).

Employed an iterative algorithm for Healthcare WSNs benefit from both encryption and blockchain technology". Blockchain technology and intrusion detection systems (IDS), together with anomaly detection algorithms and techniques. It alerts the network Administrator to reduce potential risk It guarantees the optimal result on Network anomalies detected through machine

learning enhanced anomaly detection algorithms, which examine data transmission patterns to find patterns that deviate from the norm. It is time and space-consuming. Inconsistent when compared with other traditional algorithms. Radhappa *et al.* (2024).

Energy-Efficient Architecture (ARC) for WSNs in Healthcare Applications (HA) / A quaternary (QTR) interconnect ARC that can modify the transmission of data in a WSN for mobile multimedia and (HAs) from binary symbols to (QTR) one. Using a ternary numbering system is complex, and it needs more calculations due to the difference in the base, thus requiring more computations and energy consumption / CBEES) For WSNs will be reduced by the reduction of Energy. High Energy consumption and delay. Abdallah *et al.* (2023) RNS-Based Approach to Minimize Energy Consumption in WSNs/ Forward and Reverse converters are proposed for message encoding and decoding at the cluster head and base station. There is Energy Limitation and improvement in network performance and energy reduction during data routing to the base station, the study does not consider reverse conversion by sensor nodes. Yakubu Abdul-Wahab Nawusu *et al* (2024)

### **Significant of WSN in healthcare application system.**

The healthcare system achieves faster accurate real-time data assessments through RNS thus enabling timely medical intervention and superior patient results. In critical care medicine RNS offers fast processing capabilities to analyze patient vital signs thus enabling medical staff to identify and respond rapidly to potentially dangerous medical situations.

The limited battery capacity of sensor nodes in WSN-based healthcare systems remains a critical issue because efficiency in energy usage must be maximized. Traditional arithmetic operations use excessive amount of computational power that remains a major barrier to the sustainable operation of such networks. Extending operational lifespans of sensor nodes occurs through using RNS-based calculations to decrease processing cycle requirements for arithmetic operations thus allowing remote patient monitoring in limited resource environments. RNS-based calculations prove useful in unchangeable patient monitoring settings because battery replacements become impractical and infeasible. The extended durability of sensor nodes enabled by RNS technology enables ongoing and untainted patient surveillance which produces better healthcare results together with lower healthcare expenses.

Furthermore, this work is also to improve security and data integrity in healthcare WSNs due to how medical data is sensitive and confidentiality, authenticity and integrity of data is crucial to protect patient privacy and comply with healthcare regulations. Another major contribution of this work is to improve security and data integrity in healthcare WSNs due to how medical data is sensitive and confidentiality, authenticity and integrity of data is crucial to protect patient privacy and comply with healthcare regulations. Implementation of RNS leads to performance improvement in healthcare WSNs because it decreases the time needed for calculations.

RNS demonstrates superior processing capabilities when handling real-time sensor data so it suits applications that involve wearable health devices and telemedicine as well as remote patient

monitoring according to Deepa and Pandiaraja (2023). RNS accelerates the overall data processing cycle because this system processes health parameters simultaneously such as heart rate and blood pressure and glucose levels (Seba *et al.*, 2023). The implementation of Residue Number System (RNS) within Wireless Sensor Network (WSN) nodes for healthcare purposes requires nodes to use modular arithmetic instead of binary processing. The RNS integration enables healthcare WSNs to complete data processing tasks efficiently in real-time with superior speed (Lv *et al.*, 2024).

A standard healthcare WSN operates by allowing sensor nodes to gather systematic data flow. Sensor data within RNS systems gets split into smaller residue components before individual processing occurs. Because RNS enables parallel data processing at the sensor nodes they can produce actionable insights in a shorter time period (Jayaraman & Stanislaus Panneerselvam, 2023). With RNS-based power wearable devices maintain the ability to perform parallel heart rate data processing. The system provides immediate real-time alerts to medical staff because its parallel processing capability detects irregularities in emergency settings (He *et al.*, 2023).

## MATERIALS AND METHOD

Methodology used in this work is based on experimental setup software-based simulation with two tiers frame work Comprising.

- (i) WSNs System Architecture and Design
- (ii) Residue Number System Implementation in WSN using CRT Technique.

The experimental design, procedures and conduct via data collection is executed. Using analytical approach to evaluate the RNS-WSNs based performance.

Simulation tools with MATLAB was used to model WSN architectures help check in healthcare system via the network parameters: **latency, speed, accuracy, energy consumption** using define key performance **metric**. The hardware and software components implementation setup to explore Residue Number System (RNS) are compared and integrated into Wireless Sensor Networks (WSNs) for healthcare applications

### Design Scheme Wireless Sensor Network Based RNS Architecture

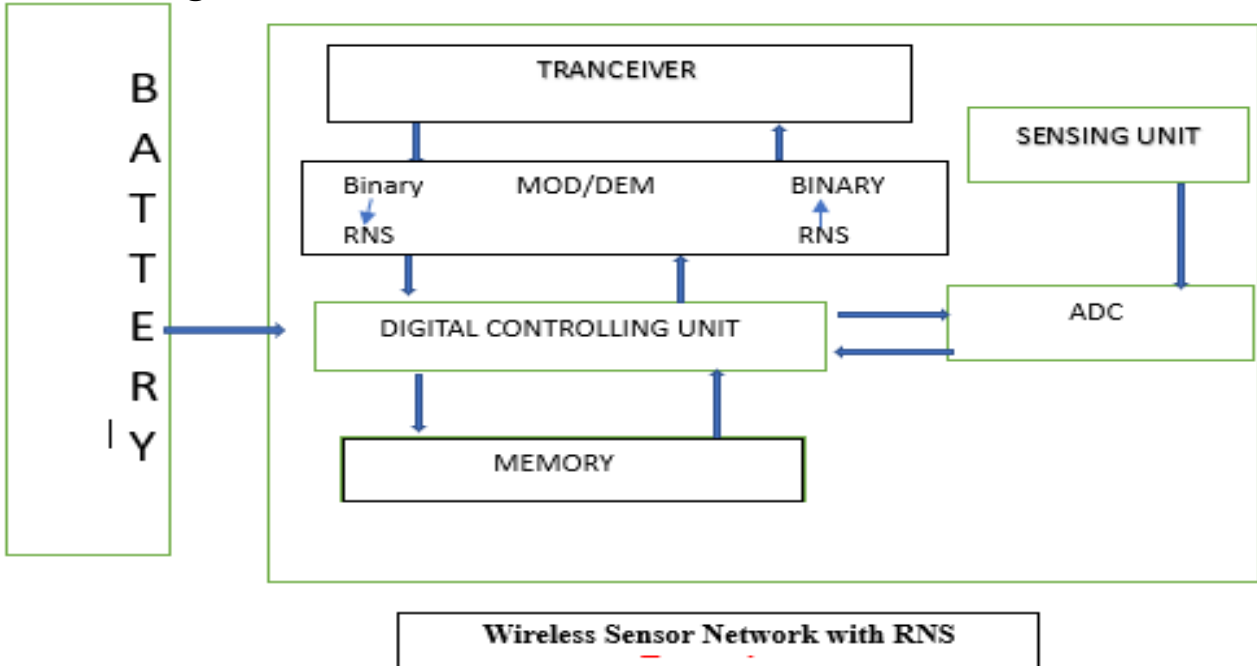

### Experimental Result

The implementation of RNS-based framework is simulated in healthcare WSN environment and displays experimental data regarding computational performance together with power usage, system reliability and defense capabilities. Secondly, this provides benchmarks between RNS performance together with standard number systems along with current WSN security practices emphasizing RNS advantages. Furthermore, experimental findings and theoretical documentation link up through explanations examines RNS effects on healthcare tracking capabilities in real time system dependability.

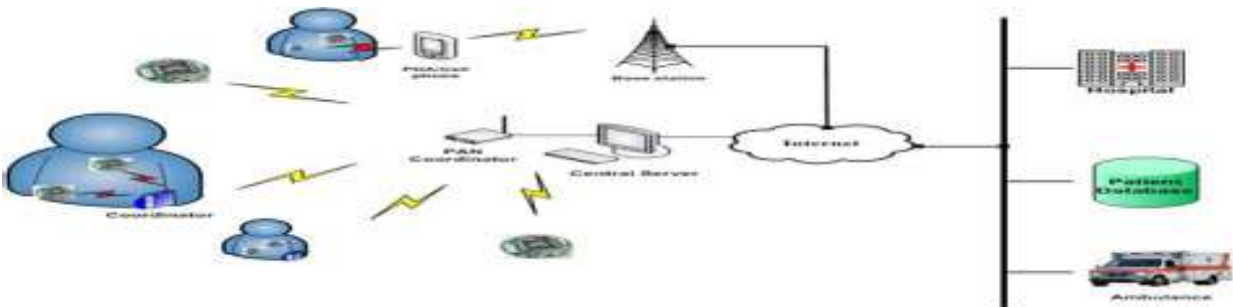

Tennina et al . (2014)

## Design Implementation Energy Efficient Modulation Algorithm (EMA) in (WSNs )

### Begin

1. BS transmits data to the gateway safely modulated using CRT
2. Data is transferred from the gateway to the medical server.
3. Data is detected by medical servers for further action.
4. for each BS GW do
5. If (BS safely receives data from the TRANSDUCER), then
6. Gateway (GW) to transport data over clouds.
7. Data is not identified by the Gateway to send over clouds
8. if (BS does not receive data from any TRANSDUCER) in specified slot).
9. End if
10. If (data from BS to Gateway) is true, then
11. Gateway clouds deliver data to the medical server.
12. End if
13. End for
14. End
- 15 End if

### Network Model Setup Parameter for Data Application Implementation

A discrete data event simulation model is developed to reflect real-world healthcare deployment conditions:

- **Node Count:** 50 to 100 sensor nodes
- **Deployment Area:** 100m × 100m field
- **Placement Strategy:** Random uniform distribution
- **Communication Range:** 25–30 meters, simulating low-power transmission
- **Routing Protocol:** Custom static routing protocol or LEACH for hierarchical clustering

This setup enables analysis of scalability, interference, and node-to-node communication efficiency.

### The Simulation Performance Data Analysis

*Input: Simulated physiological dataset (temperature, heart rate, blood pressure, glucose)*

*Output: Performance metrics (computation time, energy consumption, accuracy)*

#### 1. Initialize:

*i. Moduli set for RNS =  $(2^n - 1, 2^n, 2^n + 1)$*

*ii. Modulation for CRT = {3 4 5 }*

*iii. Performance metric trackers (time, energy, packet loss, delay, scalability, accuracy)*

#### 2. For each data record in the dataset:

*i. Extract vital signs synthetic physiological data as a list of integers*

*-- RNS Processing --*

*ii. Encode each value using RNS moduli*

*iii. Perform modular aggregation across encoded values*

*iv. Apply CRT modulation to the aggregated RNS values*

*v. Demodulate the modulated RNS values using CRT converterf. Reconstruct the original value using Chinese Remainder Theorem (CRT)*

*vi. Record RNS computation time, energy usage, and reconstruction accuracy*

### Performance Metrics Compare with Related and Design Scheme

Performance Metric	Traditional WSN Model (TWM) (Related Scheme)	RNS -WSN Model (RWM) (Design Scheme)	Performance Difference (PD)	% Difference
Avg. Processing Time (APT)	0.045/mS	0.026/mS	0.019ms	57.7
Battery Consumption Rate/m joule	2.997/mj	0.991/mj	2.006mj	66.9
Packet Loss (%)	6.5%	5.1%	1.4	21.5
Signal Strength Variability/(dbm)	4.001	1.996	2.005	50.11
Latency in Transmission/(ms)	3.978	2.001	1.977	49.69
Scalability	3.001	4.998	1.976	66.5

**Performance Metric Evaluation Between Related and Design Scheme**

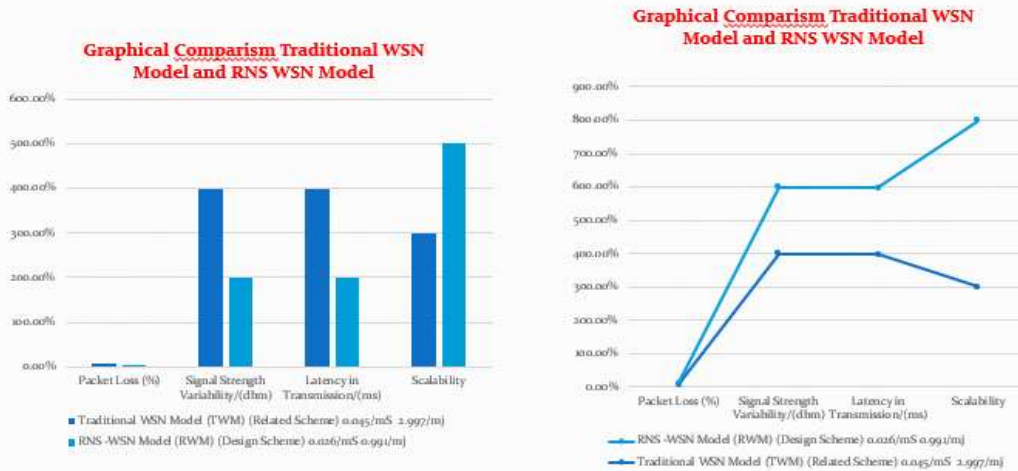

Based on the data in both the graph and the table, the RNS-WSN Model (RWM) is clearly the better option overall.

**Reasons Why RNS-WSN Model (RWM) is Better:**

Metric	RWM (Design Scheme)	Why It's Better
Avg. Processing Time	Lower (0.026 mS)	Faster processing
Battery Consumption	Lower (0.991 mJ)	More energy-efficient
Packet Loss	Lower (5.1%)	More reliable communication
Signal Strength Variability	Lower (1.996 dBm)	Stronger, more stable signal
Latency	Lower (2.001 ms)	Quicker data transmission
Scalability	Higher (4.998)	Better at handling network expansion

- **RNS-WSN Model (RWM) provides better performance, efficiency, and scalability across all major metrics.**

**CONCLUSION**

The research findings receive final synthesis in this work by demonstrating large-scale possibilities for healthcare application improvement through RNS integration with WSNs by presenting an overview of the whole system; designs research pathways and stimulates creative solution development for this field.

**Recommendation**

Future researchers can utilize this work as a guide to address various domains which include uses of RNS for reliable performance and efficient calculations as well as secure patient information

handling and framework scalability for new healthcare uses. Also, supplied research blueprint intends to enhance in healthcare WSNs application with RNS while development of artificial intelligence together with quantum computing provides essential tools for future investigations.

## REFERENCES

- Chakraborty, B., Verma, S., & Singh, K. P. (2023). Temporal differential privacy in wireless sensor networks. *Journal of Network and Computer Applications*, 155, 102548. <https://doi.org/10.1016/j.jnca.2020.102548>
- Radhappa, H., Pan, L., Zheng, J., & Wen, S. (2024). Practical overview of security issues in wireless sensor network applications. *International Journal of Computer Applications*, 40(4), 202–213. <https://doi.org/10.1080/1206212X.2017.1398214>
- Seba, A., Nouali-Taboudjemat, N., Badache, N., & Seba, H. (2023). A review on security challenges of wireless communications in disaster emergency response and crisis management situations. *Journal of Network and Computer Applications*, 126, 150–161.
- Lv, Y., Liu, Y., & Hua, J. (2024). A study on the application of WSN positioning technology to unattended areas. *IEEE Access*, 7, 38085–38099. <https://doi.org/10.1109/ACCESS.2019.2908981>
- He, M., Guan, Z., Wu, Z., et al. (2023). A polling access control with exhaustive service in wireless body area networks for mobile healthcare using the sleeping schema. *Journal of Ambient Intelligence and Humanized Computing*, 10(8), 3761–3774. <https://doi.org/10.1007/s12652-019-01411-w>
- Jayaraman, I., & Stanislaus Panneerselvam, A. (2023). A novel privacy-preserving digital forensic readiness provable data possession technique for healthcare data in the cloud. *Journal of Ambient Intelligence and Humanized Computing*, 10(12), 4151–4166. <https://doi.org/10.1007/s12652-017-0659-1>
- S. Tennina, m. Di Renzo, F.graziosi (2014) . WSN - ORIENTED HEALTHCARE SYSTEM ARCHITECTURE  
INTERNATIONAL JOURNAL OF DISTRIBUTED SENSOR NETWORKS  
<https://doi.org/10.1155/2014/503417>
- Kushala, M. V., & Shylaja, B. S. (2020). Recent trends on security issues in multi-cloud computing: A survey. In *2020 International Conference on Smart Electronics and Communication (ICOSEC)* (pp. 777–781). IEEE.
- S.Tennina. M Di Renzo , E . Kartsakli , (2014). Wireless sensor network oriented healthcare system architecture (international journal of distributed sensors networks) Doi: 10.1155/2014/503417
- Bryan Raj , Ismail Ahmedy, Mohd Yamani Idna Idris , and Rafidah Md. (2023) A Survey on Cluster Head Selection and Cluster Formation Methods in Wireless Sensor Network  
Wireless Communications and Mobile Computing Volume 2022, Article ID 5322649, 53 pages  
<https://doi.org/10.1155/2022/5322649>